



**Industrial Grade  
-940S series  
mSATA SSD**

**Product Manual**

*January 7, 2022*

**[www.cactus-tech.com](http://www.cactus-tech.com)**

*The information in this manual is preliminary and is subject to change without notice. Cactus Technologies<sup>®</sup>, Limited shall not be liable for technical or editorial errors or omissions contained herein; nor for incidental or consequential damages resulting from the furnishing, performance, or use of this material.*

*Cactus Technologies<sup>®</sup> makes no warranty, representation or guarantee regarding the suitability of its products for any particular purpose, nor does Cactus Technologies<sup>®</sup> assume any liability arising out of the application or use of its products, and specifically disclaims any and all liability, including without limitation consequential or incidental damages.*

*Cactus Technologies<sup>®</sup> products are not designed, intended or authorized for use as components in systems intended for surgical implant into the body or in other applications intended to support or sustain life or for any application where the failure of a Cactus Technologies<sup>®</sup> product can result in personal injury or death. Users of Cactus Technologies<sup>®</sup> products for such unintended and unauthorized applications shall assume all risk of such use and shall indemnify and hold Cactus Technologies<sup>®</sup> and its officers, employees, subsidiaries, affiliates and distributors harmless against all claims, costs, damages, expenses and attorney fees arising out of, directly or indirectly, any claim of personal injury or death associated with such unintended and unauthorized use, even if such claim alleges that Cactus Technologies<sup>®</sup> was negligent regarding the design or manufacture of the part.*

*All parts of the Cactus Technologies<sup>®</sup> documentation are protected by copyright law and all rights are reserved. This documentation may not, in whole or in part, be copied, photocopied, reproduced, translated, or reduced to any electronic medium or machine-readable form without prior consent, in writing, from Cactus Technologies<sup>®</sup>, Limited.*

*© 2005-2022 Cactus Technologies<sup>®</sup> Limited. All rights reserved.*

## Table of Contents

1. Introduction to Cactus Technologies® Industrial Grade -940S Series mSATA SSD Products.....	5
1.1. Supported Standards.....	6
1.2. Product Features.....	6
1.2.1. Host and Technology Independence.....	6
1.2.2. Defect and Error Management.....	6
1.2.3. Power Supply Requirements.....	7
2. Product Specifications.....	7
2.1. System Environmental Specifications.....	7
2.2. System Power Requirements.....	7
2.3. System Performance.....	8
2.4. System Reliability.....	8
2.5. Physical Specifications.....	8
2.5.1. mSATA SSD Physical Specifications.....	9
3. Interface Description.....	14
3.1. mSATA SSD Pin Assignments and Pin Type.....	14
4. Electrical Specifications.....	15
4.1.1. Absolute Maximum Ratings.....	16
4.1.2. DC Characteristics.....	16
4.1.3. AC Characteristics.....	16
5. ATA Drive Register Set Definition and Protocol.....	16
5.1. ATA Task File Definitions.....	17
5.1.1. Data Register.....	17
5.1.2. Error Register.....	17
5.1.3. Feature Register.....	17
5.1.4. Sector Count Register.....	17
5.1.5. Sector Number (LBA 7-0) Register.....	17
5.1.6. Cylinder Low (LBA 15-8) Register.....	18
5.1.7. Cylinder High (LBA 23-16) Register.....	18
5.1.8. Drive/Head (LBA 27-24) Register.....	18
5.1.9. Status Registers.....	18
5.1.10. Device Control Register.....	19
5.1.11. Drive Address Register.....	19
6. ATA Command Description.....	20
6.1. ATA Command Set.....	20
7. S.M.A.R.T. Feature Set.....	21
7.1. S.M.A.R.T Data Structure.....	21
7.2. S.M.A.R.T Attributes.....	22
Appendix A. Ordering Information.....	24
Appendix B. Technical Support Services.....	25
Appendix C. Cactus Technologies® Worldwide Sales Offices.....	26

Appendix D. Limited Warranty.....27

# 1. Introduction to Cactus Technologies® Industrial Grade -940S Series mSATA SSD Products

## Features:

- Solid state design with no moving parts
- Capacities from 8GB to 128GB
- Compliant with Serial ATA 3.1 specifications
- ATA-8 ACS2 compatible
- Supports Serial ATA Generation I/II/III transfer rate of 1.5/3.0/6.0 Gbps
- Supports ATA SMART Feature Set
- Supports ATA Security Feature Set
- Supports Data Set Management (TRIM)
- Supports NCQ w/ max. queue depth of 32
- Supports DevSLP
- ECC capable of correcting up to 66 bit errors per 1KB
- Enhanced error correction, < 1 error in 10<sup>14</sup> bits read
- Voltage support: 3.3V±5%

Cactus Technologies® Industrial mSATA SSD is a high capacity solid-state flash memory product that complies with the Serial ATA 3.1 standard and is functionally compatible with a SATA hard disk drive. Cactus Technologies® -940S series Industrial mSATA SSD provide up to 128GB of formatted storage capacity.

Cactus Technologies® Industrial mSATA SSD product uses high quality MLC NAND flash memory from Kioxia Corporation. In addition, it includes an on-drive intelligent controller that manages interface protocols, data storage and retrieval as well as ECC, defect handling and diagnostics, power management, and clock control. The controller's firmware is upgradeable, thus allowing feature enhancements and firmware updates while keeping the BOM stable.

## 1.1. Supported Standards

Cactus Technologies® mSATA SSD is fully compatible with the following specification:

- ATA 8/ACS2 Specification published by ANSI
- Serial ATA 3.1 Specification published by the Serial ATA International Organization

## 1.2. Product Features

Cactus Technologies® Industrial mSATA SSD contains a high level, intelligent controller. This intelligent controller provides many capabilities including the following:

- Standard ATA register and command set (same as found on most magnetic disk drives).
- Manages details of erasing and programming flash memory independent of the host system
- Sophisticated defect managing capabilities (similar to magnetic disk drives).
- Sophisticated system for error recovery using powerful error correction code (ECC).
- Intelligent power management for low power operation.

### 1.2.1. Host and Technology Independence

Cactus Technologies® Industrial mSATA SSD appears as a standard SATA disk drive to the host system. The drive utilizes a 512-byte sector which is the same as that in an IDE magnetic disk drive. To write or read a sector (or multiple sectors), the host computer software simply issues an ATA Read or Write command to the drive as per the SATA protocol. The host software then waits for the command to complete. The host system does not get involved in the details of how the flash memory is erased, programmed or read as this is all managed by the built-in controller in the drive. Also, with the intelligent on-board controller, the host system software will not require changing as new flash memory evolves. Thus, systems that support the Cactus Technologies® Industrial mSATA SSD products today will continue to work with future Cactus Technologies® Industrial mSATA SSDs built with new flash technology without having to update or change host software.

### 1.2.2. Defect and Error Management

Cactus Technologies® Industrial mSATA SSD contains a sophisticated defect and error management system similar to those found in magnetic disk drives. The defect management is completely transparent to the host and does not consume any user data space.

The soft error rate for Cactus Technologies® Industrial mSATA SSD is much lower than that of magnetic disk drives. In the extremely rare case where a read error does occur, the drive has sophisticated ECC to recover the data.

These defect and error management systems, coupled with the solid-state construction, give Cactus Technologies® Industrial mSATA SSDs unparalleled reliability.

### 1.2.3. Power Supply Requirements

Cactus Technologies® Industrial mSATA SSD operates at a voltage range of 3.3 volts ± 5%.

## 2. Product Specifications

For all the following specifications, values are defined at ambient temperature and nominal supply voltage unless otherwise stated.

### 2.1. System Environmental Specifications

**Table 2-1. Environmental Specifications**

		Cactus Technologies® Industrial mSATA SSD
<b>Temperature</b>	Operating:	0° C to +70° C (Standard) -40° C to +85° C (Extended)
<b>Humidity</b>	Operating & Non-Operating:	8% to 95%, non-condensing
<b>Vibration</b>	Operating & Non-Operating:	20G, MIL-STD-883G Method 2005.2, Condition A
<b>Shock</b>	Operating & Non-Operating:	3,000 G, MIL-STD-883G Method 2002.4, Condition C
<b>Altitude (relative to sea level)</b>	Operating & Non-Operating:	100,000 feet maximum

### 2.2. System Power Requirements

**Table 2-2. Power Requirements**

		Cactus Technologies® Industrial mSATA SSD				
		8GB	16GB	32GB	64GB	128GB
<b>DC Input Voltage (VCC)</b> <b>100 mV max. ripple (p-p)</b>		3.3V ±5%				
<b>(Maximum Average Value) mA</b> <b>See Notes.</b>	Idle:	85	85	90	95	105
	Reading:	240	260	325	345	685
	Writing:	255	300	420	465	870

**NOTES:** All values quoted are typical at ambient temperature and nominal supply voltage unless otherwise stated.

Sleep mode is specified under the condition that all drive inputs are static CMOS levels and in a “Not Busy” operating state.

## 2.3. System Performance

All performance timings assume the drive controller is in the default (i.e., fastest) mode.

**Table 2-3. Performance**

	8GB	16GB	32GB	64GB	128GB
<b>Read Transfer Rate (MB/s)</b>	80	85	165	170	540
<b>Write Transfer Rate (MB/s)</b>	40	75	150	160	415

## 2.4. System Reliability

**Table 2-4. Reliability**

Data Reliability	< 1 non-recoverable error in 10 <sup>14</sup> bits READ
Endurance (estimated TBW):	
8GB	480TB
16GB	960TB
32GB	1920TB
64GB	3840TB
128GB	7680TB

*Note: estimated TBW assumes workload consisting of mostly large block writes*

## 2.5. Physical Specifications

The following sections provide the physical specifications for Cactus Technologies® Industrial mSATA SSD products.



**2.5.1. mSATA SSD Physical Specifications**

1. mSATA FULL SIZE  
VARIATION A

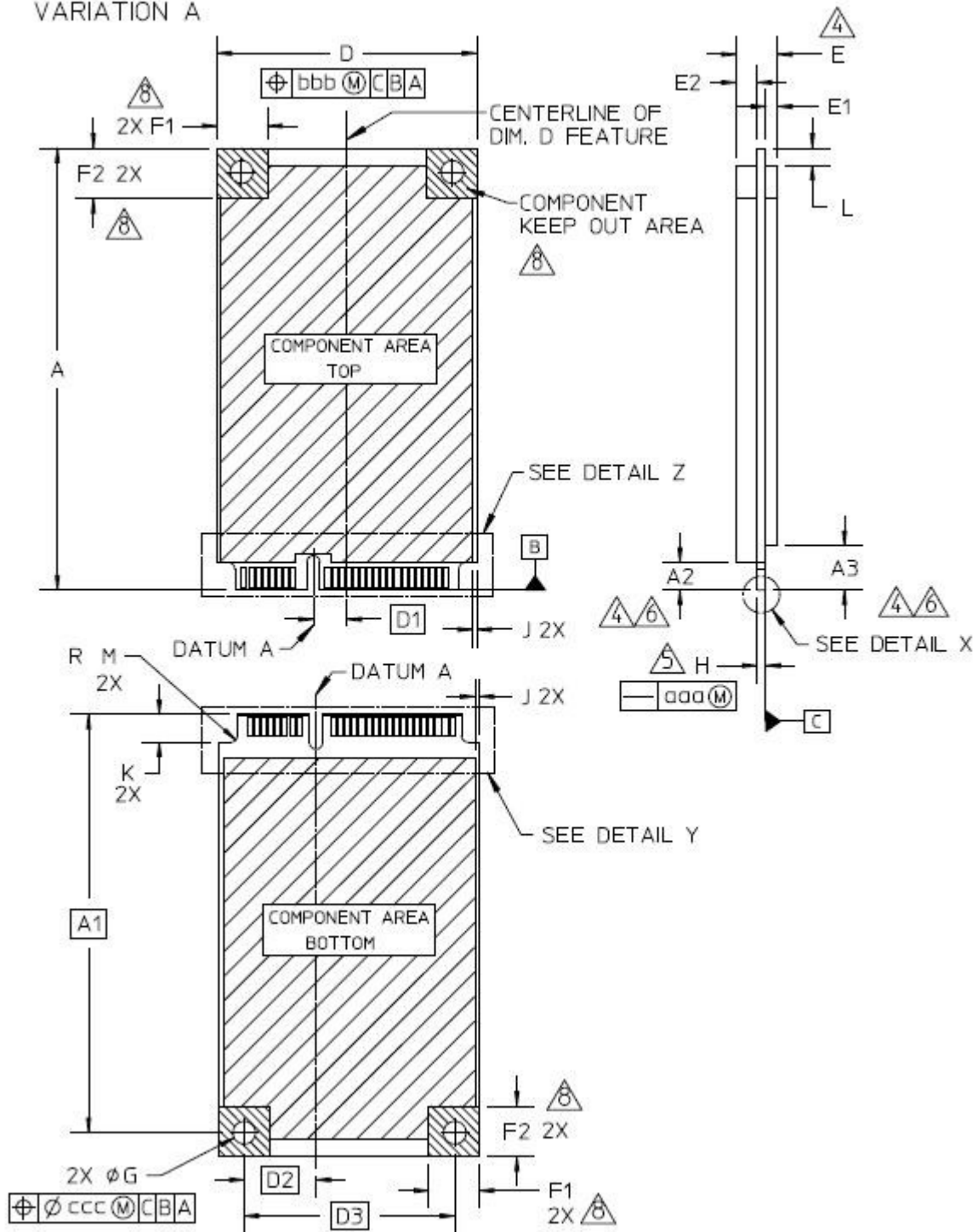

**2-1. 2.5" SSD Dimensions**

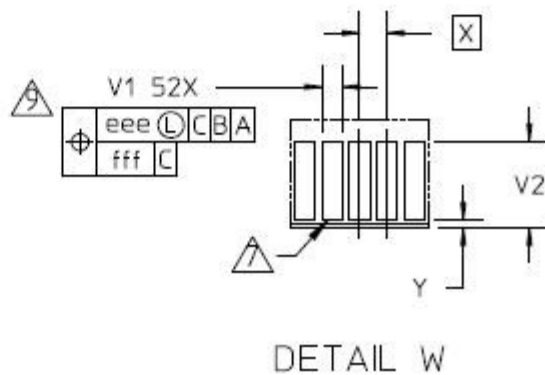
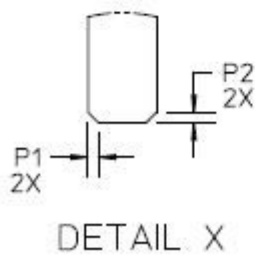
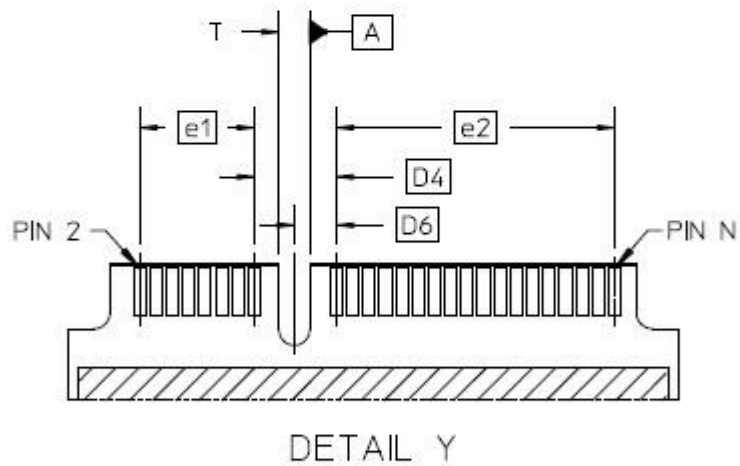
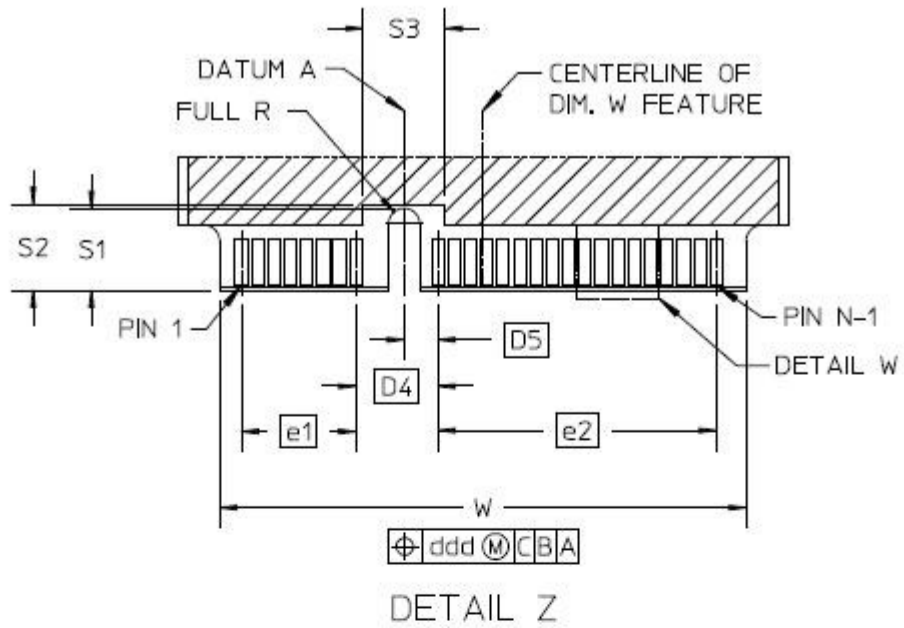

TABLE 1

COMMON DIMENSION TABLE				
SYMBOL	MIN	NOM	MAX	NOTES
A2	3.20	–	–	4,6
A3	5.10	–	–	4,6
D	29.70	29.85	30.00	
G	2.50	2.60	2.70	
H	0.90	1.00	1.10	5
J	0.50	–	–	
K	3.20	–	–	
M	–	–	0.80	
P1	–	–	0.25	
P2	–	–	0.25	
S1	3.90	4.00	4.10	
S2	4.20	–	–	
S3	4.00	–	–	
T	1.40	1.50	1.60	
V1	0.55	0.60	0.65	
V2	2.40	2.55	2.70	
W	25.55	25.70	25.85	
Y	–	–	0.25	
N		52		
ISSUE	A			
REF	14-131			
NOTES	1, 2, 3			

TABLE 2

GD&T BASIC DIMENSIONS		
SYMBOL	VALUE	NOTES
D1	3.85	
D2	8.25	
D3	24.20	
D4	4.00	
D5	1.65	
D6	2.05	
e1	5.60	
e2	13.60	
X	0.80	
ISSUE	A	
REF	14-131	
NOTES	1, 2, 3	

TABLE 3

TOLERANCES OF FORM AND POSITION		
SYMBOL	VALUE	NOTES
aaa	0.22	
bbb	0.10	
ccc	0.10	
ddd	0.10	
eee	0.10	
fff	0.05	
ISSUE	A	
REF	14-131	
NOTES	1, 2, 3	

TABLE 4

mSATA FULL SIZE VARIATION A			
SYMBOL	MIN	NOM	MAX
A	50.65	50.80	50.95
A1	48.05 BASIC		
E	-	-	4.85
E1	-	-	1.35
E2	-	-	2.40
F	-	-	-
F1	5.65	5.80	5.95
F2	5.65	5.80	5.95
L	2.00	-	-
ISSUE	A		
REF	14-131		
NOTES	1, 2, 3		

NOTES :

1. DIMENSIONING AND TOLERANCING CONFORM TO ASME Y14.5M-1994
2. TOLERANCES ON ALL DIMENSIONS  $\pm 0.15$  UNLESS OTHERWISE SPECIFIED.
3. ALL DIMENSIONS ARE IN MILLIMETERS, UNLESS OTHERWISE SPECIFIED.
4. DIMENSIONS APPLICABLE WHEN COMPONENTS ARE MOUNTED ON BOTH SIDES.
5. CARD THICKNESS APPLIES ACROSS TABS AND INCLUDES PLATING AND/OR METALIZATION.
6. BORDER OF COMPONENT AREA.
7. EDGE OF CONTACT PADS SHALL BE FREE OF BURRS AND EXTERNAL TIE BARS.
8. COMPONENT AND ROUTING (TOP/BOTTOM LAYER) KEEP OUT AREA FOR HOLD DOWN SOLUTIONS.

## 3.Interface Description

The following sections provide detailed information on the Cactus Technologies® Industrial mSATA SSD interface.

### 3.1. mSATA SSD Pin Assignments and Pin Type

The signal/pin assignments and descriptions are listed in Table 3-5.

**Table 3-5. mSATA SSD Pin Assignments and Pin Type**

Pin #	Pin Name	Description	Pin #	Pin Name	Description
1	Reserved		2	3.3V	3.3V supply
3	Reserved		4	GND	
5	Reserved		6	NC	Reserved for 1.5V supply
7	Reserved		8	Reserved	

Pin #	Pin Name	Description	Pin #	Pin Name	Description
9	GND		10	Reserved	
11	Reserved		12	Reserved	
13	Reserved		14	Reserved	
15	GND		16	Reserved	
17	Reserved		18	GND	
19	Reserved		20	Reserved	
21	GND		22	Reserved	
23	RX+	Host Receiver Differential Plus	24	3.3V	3.3V supply
25	RX-	Host Receiver Differential Minus	26	GND	
27	GND		28	NC	Reserved for 1.5V supply
29	GND		30	I2C_CLK	Two wire interface clock
31	TX-	Host Transmitter Differential Minus	32	I2C_DAT	Two wire interface data
33	TX+	Host Transmitter Differential Plus	34	GND	
35	GND		36	Reserved	
37	GND		38	Reserved	
39	3.3V	3.3V supply	40	GND	
41	3.3V	3.3V supply	42	Reserved	
43	Device Type	No connect for mSATA	44	DEVSLP	DevSleep control
45	Vendor	Vendor specific pin	46	Reserved	
47	Vendor	Vendor specific pin	48	NC	Reserved for 1.5V supply
49	DAS/DSS	Device Activity signal	50	GND	
51	Presence Detect	Tied to GND in device	52	3.3V	3.3V supply

## 4. Electrical Specifications

The following table defines all D.C. Characteristics for the mSATA SSD products. Unless otherwise stated, conditions are:

$$V_{cc} = 3.3V \pm 5\%$$

$$T_a = -40^{\circ}C \text{ to } 85^{\circ}C$$

### 4.1.1. Absolute Maximum Ratings

Parameter	Symbol	MIN	MAX	Units
Storage Temperature	T <sub>s</sub>	-55	+100	°C
Operating Temperature	T <sub>A</sub>	-40	+85	°C
Vcc with respect to GND	V <sub>cc</sub>	-0.3	3.6	V

### 4.1.2. DC Characteristics

Parameter	Symbol	MIN	MAX	Units
Input Voltage	V <sub>in</sub>	-0.5	V <sub>cc</sub> + 0.5	V
Output Voltage	V <sub>out</sub>	-0.3	V <sub>cc</sub> + 0.3	V
Input Leakage Current	I <sub>LI</sub>	-10	10	uA
Output Leakage Current	I <sub>LO</sub>	-10	10	uA
Input/Output Capacitance	C <sub>i</sub> /C <sub>o</sub>		10	pF
Operating Current	I <sub>cc</sub>			mA
Idle			110	
Active			875	

### 4.1.3. AC Characteristics

Cactus Technologies® mSATA SSD products conforms to all AC timing requirements as specified in the SATA-IO specifications. Please refer to that document for details of AC timing for all operation modes of the device.

## 5.ATA Drive Register Set Definition and Protocol

The communication to or from the SSD is done using FIS. Legacy ATA protocol is supported by using the legacy mode defined in the SATA specifications. In this mode, the FIS has defined fields which provide all the necessary ATA task file registers for control and status information. The Serial ATA interface does not support Primary/Secondary or Master/Slave configurations. Each SATA channel supports only one SATA device, with the register selection as defined by the ATA standard.



## 5.1. ATA Task File Definitions

The following sections describes the usage of the ATA task file registers. Note that the Alternate Status Register of legacy ATA is not defined for SATA drives.

### 5.1.1. Data Register

The Data Register is a 16-bit register, and it is used to transfer data blocks between the SSD data buffer and the Host.

### 5.1.2. Error Register

This register contains additional information about the source of an error when an error is indicated in bit 0 of the Status register. The bits are defined as follows:

D7	D6	D5	D4	D3	D2	D1	D0
BBK	UNC	0	IDNF	0	ABRT	0	AMNF

- Bit 7 (BBK)** This bit is set when a Bad Block is detected.
- Bit 6 (UNC)** This bit is set when an Uncorrectable Error is encountered.
- Bit 5** This bit is 0.
- Bit 4 (IDNF)** The requested sector ID is in error or cannot be found.
- Bit 3** This bit is 0.
- Bit 2 (Abort)** This bit is set if the command has been aborted because of a status condition: (Not Ready, Write Fault, etc.) or when an invalid command has been issued.
- Bit 1** This bit is 0.
- Bit 0 (AMNF)** This bit is set in case of a general error.

### 5.1.3. Feature Register

This register provides information regarding features of the SSD that the host can utilize.

### 5.1.4. Sector Count Register

This register contains the number of sectors of data requested to be transferred on a read or write operation between the host and the SSD. If the value in this register is zero, a count of 256 sectors is specified. If the command was successful, this register is zero at command completion. If not successfully completed, the register contains the number of sectors that need to be transferred in order to complete the request.

### 5.1.5. Sector Number (LBA 7-0) Register

This register contains the starting sector number or bits 7-0 of the Logical Block Address (LBA) for any SSD data access for the subsequent command.

### 5.1.6. Cylinder Low (LBA 15-8) Register

This register contains the low order 8 bits of the starting cylinder address or bits 15-8 of the Logical Block Address.

### 5.1.7. Cylinder High (LBA 23-16) Register

This register contains the high order bits of the starting cylinder address or bits 23-16 of the Logical Block Address.

### 5.1.8. Drive/Head (LBA 27-24) Register

The Drive/Head register is used to select the drive and head. It is also used to select LBA addressing instead of cylinder/head/sector addressing. The bits are defined as follows:

D7	D6	D5	D4	D3	D2	D1	D0
1	LBA	1	DRV	HS3	HS2	HS1	HS0

**Bit 7** This bit is set to 1.

**Bit 6** LBA is a flag to select either Cylinder/Head/Sector (CHS) or Logical Block Address Mode (LBA). When LBA=0, Cylinder/Head/Sector mode is selected. When LBA=1, Logical Block Address is selected. In Logical Block Mode, the Logical Block Address is interpreted as follows:  
 LBA07-LBA00: Sector Number Register D7-D0.  
 LBA15-LBA08: Cylinder Low Register D7-D0.  
 LBA23-LBA16: Cylinder High Register D7-D0.  
 LBA27-LBA24: Drive/Head Register bits HS3-HS0.

**Bit 5** This bit is set to 1.

**Bit 4 (DRV)** DRV is the drive number. This should always be set to 0.

**Bit 3 (HS3)** When operating in the Cylinder, Head, Sector mode, this is bit 3 of the head number. It is Bit 27 in the Logical Block Address mode.

**Bit 2 (HS2)** When operating in the Cylinder, Head, Sector mode, this is bit 2 of the head number. It is Bit 26 in the Logical Block Address mode.

**Bit 1 (HS1)** When operating in the Cylinder, Head, Sector mode, this is bit 1 of the head number. It is Bit 25 in the Logical Block Address mode.

**Bit 0 (HS0)** When operating in the Cylinder, Head, Sector mode, this is bit 0 of the head number. It is Bit 24 in the Logical Block Address mode.

### 5.1.9. Status Registers

These registers return the status when read by the host. Reading the Status register does clear a pending interrupt while reading the Auxiliary Status register does not. The meaning of the status bits are described as follows:

D7	D6	D5	D4	D3	D2	D1	D0
BUSY	RDY	DWF	DSC	DRQ	CORR	0	ERR

- Bit 7 (BUSY)** The busy bit is set when the device has access to the command buffer and registers and the host is locked out from accessing the command register and buffer. No other bits in this register are valid when this bit is set to a 1.
- Bit 6 (RDY)** RDY indicates whether the device is capable of performing operations requested by the host. This bit is cleared at power up and remains cleared until the device is ready to accept a command.
- Bit 5 (DWF)** This bit, if set, indicates a write fault has occurred.
- Bit 4 (DSC)** This bit is set when the device is ready.
- Bit 3 (DRQ)** The Data Request is set when the device requires that information be transferred either to or from the host through the Data register.
- Bit 2 (CORR)** This bit is set when a Correctable data error has been encountered and the data has been corrected. This condition does not terminate a multi-sector read operation.
- Bit 1 (IDX)** This bit is always set to 0.
- Bit 0 (ERR)** This bit is set when the previous command has ended in some type of error. The bits in the Error register contain additional information describing the error.

### 5.1.10. Device Control Register

This register is used to control the drive interrupt request and to issue an ATA soft reset to the drive. The bits are defined as follows:

D7	D6	D5	D4	D3	D2	D1	D0
HOB	X	X	X	1	SW Rst	-IEn	0

- Bit 7** This bit is used in 48-bit addressing mode. When cleared, the host can read the most recently written values of the Sector Count, Drive/Head and LBA registers. When set, the host will read the previous written values of these registers. A write to any Command block register will clear this bit.
- Bit 6** This bit is an X (Do not care).
- Bit 5** This bit is an X (Do not care).
- Bit 4** This bit is an X (Do not care).
- Bit 3** This bit is ignored by the drive.
- Bit 2 (SW Rst)** This bit is set to 1 in order to force the drive to perform an AT Disk controller Soft Reset operation. The drive remains in Reset until this bit is reset to '0'.
- Bit 1 (-IEn)** The Interrupt Enable bit enables interrupts when the bit is 0. When the bit is 1, interrupts from the drive are disabled. This bit is set to 0 at power on and Reset.
- Bit 0** This bit is ignored by the drive.

### 5.1.11. Drive Address Register

This register is provided for compatibility with the AT disk drive interface. It is recommended that this register not be mapped into the host's I/O space because of potential conflicts on Bit 7. The bits are defined as follows:

D7	D6	D5	D4	D3	D2	D1	D0
X	-WTG	-HS3	-HS2	-HS1	-HS0	-nDS1	-nDS0

- Bit 7** This bit is unknown.  
Implementation Note:

Conflicts may occur on the host data bus when this bit is provided by a Floppy Disk Controller operating at the same addresses as the SSD. Following are some possible solutions to this problem:

1. Locate the SSD at a non-conflicting address (i.e., Secondary address (377) when a Floppy Disk Controller is located at the Primary addresses).
2. Do not install a Floppy and a SSD in the system at the same time.
3. Implement a socket adapter that can be programmed to (conditionally) tri-state D7 of I/O address 3F7/377 when a SSD product is installed and conversely to tri-state D6-D0 of I/O address 3F7/377 when a floppy controller is installed.
4. Do not use the SSD's Drive Address register. This may be accomplished by either a) If possible, program the host adapter to enable only I/O addresses 1F0-1F7, 3F6 (or 170-177, 176) to the SSD or b) if provided use an additional Primary/Secondary configuration in the SSD that does not respond to accesses to I/O locations 3F7 and 377. With either of these implementations, the host software must not attempt to use information in the Drive Address Register.

- Bit 6 (-WTG)** This bit is 0 when a write operation is in progress, otherwise, it is 1.
- Bit 5 (-HS3)** This bit is the negation of bit 3 in the Drive/Head register.
- Bit 4 (-HS2)** This bit is the negation of bit 2 in the Drive/Head register.
- Bit 3 (-HS1)** This bit is the negation of bit 1 in the Drive/Head register.
- Bit 2 (-HS0)** This bit is the negation of bit 0 in the Drive/Head register.
- Bit 1 (-nDS1)** This bit is 0 when drive 1 is active and selected.
- Bit 0 (-nDS0)** This bit is 0 when the drive 0 is active and selected.

## 6.ATA Command Description

This section defines the ATA command set supported by Cactus Technologies® mSATA SSDs.

### 6.1. ATA Command Set

Table 5-6 summarizes the supported ATA command set .

**Table 5-6. ATA Command Set**

COMMAND	Code
Check Power Mode	E5h, 98h
Data Set Management	06h
Execute Drive Diagnostic	90h
Flush Cache	E7h
Flush Cache Ext	EAh
Identify Drive	ECh
Idle	E3h, 97h
Idle Immediate	E1h, 95h
Initialize Drive Parameters	91h
NOP	00h
Read Buffer	E4h
Read DMA	C8h
Read DMA Ext	25h
Read FPDMA Queued	60h
Read Multiple	C4h
Read Multiple Ext	29h
Read Sector(s)	20h, 21h
Read Sector(s) Ext	24h

COMMAND	Code
Read Verify Sector(s)	40h, 41h
Read Verify Sector(s) Ext	42h
Security Disable Password	F6h
Security Erase Prepare	F3h
Security Erase Unit	F4h
Security Freeze Lock	F5h
Security Set Password	F1h
Security Unlock	F2h
Seek	70h
Set Features	EFh
Set Multiple Mode	C6h
Set Sleep Mode	E6h, 99h
SMART	B0h
Stand By	E2h, 96h
Stand By Immediate	E0h, 94h
Write Buffer	E8h
Write DMA	CAh
Write DMA Ext	35h
Write FPDMA Queued	61h
Write Multiple	C5h
Write Multiple Ext	39h
Write Sector(s)	30h, 31h
Write Sector(s) Ext	34h

## 7. S.M.A.R.T. Feature Set

Cactus Technologies® -940 Series mSATA SSD supports S.M.A.R.T. attribute reporting. This following subcommands are supported when programmed into the Feature Register:

Value	Command	Value	Command
D0h	Read Data	D5h	Reserved
D1h	Read Attribute Threshold	D6h	Reserved
D2h	Enable/Disable Autosave	D8h	Enable SMART operations
D3h	Save Attribute Values	D9h	Disable SMART operations
D4h	Execute OFF-LINE Immediate	DAh	Return Status

### 7.1. S.M.A.R.T Data Structure

The Read Data commands returns 512 bytes of data in the following structure:

Byte	Description
0-1	Revision code
2-361	Vendor specific
362	Off-line data collection status
363	Self-test execution status byte
364-365	Total time in seconds to complete off-line data collection activities
366	Vendor specific
367	Off-line data collection capabilities
368-369	SMART capabilities
370	Error logging capabilities: bit[7:1] – reserved; bit[0]: 1=device error logging supported
371	Vendor specific
372	Short self-test routine recommended polling time (in minutes)
373	Extended self-test routine recommended polling time (in minutes)
374	Conveyance self-test routine recommended polling time (in minutes)
375-385	Reserved
386-395	Firmware Version/Date Code
396-397	Reserved
398-399	Reserved
400-405	'SM2244'
406-510	Vendor specific
511	Data structure checksum

## 7.2. S.M.A.R.T Attributes

The following table lists the attributes returned in bytes 2-361 of the 512-byte SMART data. Byte 0 is Attribute ID, bytes 1-2 are status flags, bytes 3-4 are reserved bytes; the table below shows the definition for bytes 5-11:

Attribute ID	Attribute values							Attribute Name
	Byte 5	Byte 6	Byte 7	Byte 8	Byte 9	Byte 10	Byte 11	
01h	MSB	00	00	00	00	00	00	Read error rate
05h	LSB	MSB	00	00	00	00	00	Reallocated sectors count
09h	LSB			MSB	00	00	00	Power on hours
0Ch	LSB			MSB	00	00	00	Power cycle count
A0h	LSB			MSB	00	00		Uncorrectable sector count when read/write

Attribute ID	Attribute values							Attribute Name
A1h	LSB	MSB	00	00	00	00	00	Number of valid spare block
A3h	LSB	MSB	00	00	00	00	00	Number of initial invalid block
A4h	LSB			MSB	00	00	00	Total erase count
A5h	LSB			MSB	00	00	00	Max. Erase count
A6h	LSB			MSB	00	00	00	Min. Erase count
A7h	LSB			MSB	00	00	00	Average erase count
A8h	LSB			MSB	00	00	00	Max. erase count spec.
A9h	LSB			MSB	00	00	00	<b><i>This attribute is not applicable for this product.</i></b>
AFh	LSB			MSB	00	00	00	Program fail count in worse die
B0h	LSB	MSB	00	00	00	00	00	Erase fail count in worst die
B1h	LSB			MSB	00	00	00	Total wear level count
B2h	LSB	MSB	00	00	00	00	00	Runtime invalid block count
B5h	LSB			MSB	00	00	00	Total program fail count
B6h	LSB	MSB	00	00	00	00	00	Total erase fail count
BBh	LSB			MSB	00	00	00	Uncorrectable error count
C0h	LSB			MSB	00	00	00	Power-off retract count
C2h	MSB	00	00	00	00	00	00	Drive temperature (°C)
C3h	LSB			MSB	00	00	00	Hardware ECC recovered
C4h	LSB			MSB	00	00	00	Reallocation event count
C6h	LSB			MSB	00	00	00	Reserved
C7h	LSB	MSB	00	00	00	00	00	UltraDMA CRC error count
F1h	LSB						MSB	Total LBAs written (in units of 32MB)
F2h	LSB						MSB	Total LBAs read (in units of 32MB)

## Appendix A. Ordering Information

Model KD~~X~~FI-940SM1

Where: ~~X~~ is drive capacities:

8G ----- 8GB  
16G ----- 16GB  
32G ----- 32GB  
64G ----- 64GB  
128G ----- 128GB

Where: ~~I~~ is temperature grade:

blank ----- standard  
~~I~~ ----- extended

Example:

- (1) 8GB mSATA SSD ----- KD8GF-940SM1
- (2) 8GB mSATA SSD extended temp. ----- KD8GFI-940SM1



# **Appendix B. Technical Support Services**

## **B.1. Direct Cactus Technologies® Technical Support**

Email: [tech@cactus-tech.com](mailto:tech@cactus-tech.com)

## **Appendix C.Cactus Technologies® Worldwide Sales Offices**

Email: [sales@cactus-tech.com](mailto:sales@cactus-tech.com)

Email: [americas@cactus-tech.com](mailto:americas@cactus-tech.com)

# Appendix D. Limited Warranty

## I. WARRANTY STATEMENT

Cactus Technologies® warrants its Industrial Grade products only to be free of any defects in materials or workmanship that would prevent them from functioning properly for five years from the date of purchase or when rated TBW is exceeded, whichever occurs first. This express warranty is extended by Cactus Technologies® Limited to customers of our products.

## II. GENERAL PROVISIONS

This warranty sets forth the full extent of Cactus Technologies® responsibilities regarding the Cactus Technologies® Industrial Grade Flash Storage Products. Cactus Technologies®, at its sole option, will repair, replace or refund the purchase price of the defective product. Cactus Technologies® guarantees our products meet all specifications detailed in our product manuals. Although Cactus Technologies® products are designed to withstand harsh environments and have the highest specifications in the industry, they are not warranted to never have failure and Cactus Technologies® does not warranty against incidental or consequential damages. Accordingly, in any use of products in life support systems or other applications where failure could cause injury or loss of life, the products should only be incorporated in systems designed with appropriate redundancy, fault tolerant or backup features.

## III. WHAT THIS WARRANTY COVERS

For products found to be defective, Cactus Technologies® will have the option of repairing, replacing or refunding the purchase price the defective product, if the following conditions are met:

- A. The defective product is returned to Cactus Technologies® for failure analysis as soon as possible after the failure occurs.
- B. An incident card filled out by the user, explaining the conditions of usage and the nature of the failure, accompanies each returned defective product.
- C. No evidence is found of abuse or operation of products not in accordance with the published specifications, or of exceeding maximum ratings or operating conditions.

All failing products returned to Cactus Technologies® under the provisions of this limited warranty shall be tested to the product's functional and performance specifications. Upon confirmation of failure, each product will be analyzed, by whatever means necessary, to determine the root cause of failure. If the root cause of failure is found to be not covered by the above provisions, then the product will be returned to the customer with a report indicating why the failure was not covered under the warranty.

This warranty does not cover defects, malfunctions, performance failures or damages to the unit resulting from use in other than its normal and customary manner, misuse, accident or neglect; or improper alterations or repairs. Cactus Technologies® Limited may repair or replace, at its discretion, any product returned by its customers, even if such product is not covered under warranty, but is under no obligation to do so.

#### **IV. RECEIVING WARRANTY SERVICE**

According to Cactus Technologies® warranty procedure, defective product should be returned only with prior authorization from Cactus Technologies® Limited. Please contact Cactus Technologies® Customer Service department (tech@cactus-tech.com) with the following information: product model number and description, nature of defect, conditions of use, proof of purchase and purchase date. If approved, Cactus Technologies® will issue a Return Material Authorization or Product Repair Authorization number with shipping instructions.