



**Industrial 3D TLC
-270PM6 series
M.2 SSD**

Product Manual

March 3, 2024

www.cactus-tech.com

The information in this manual is preliminary and is subject to change without notice. Cactus Technologies[®], Limited shall not be liable for technical or editorial errors or omissions contained herein; nor for incidental or consequential damages resulting from the furnishing, performance, or use of this material.

Cactus Technologies[®] makes no warranty, representation or guarantee regarding the suitability of its products for any particular purpose, nor does Cactus Technologies[®] assume any liability arising out of the application or use of its products, and specifically disclaims any and all liability, including without limitation consequential or incidental damages.

Cactus Technologies[®] products are not designed, intended or authorized for use as components in systems intended for surgical implant into the body or in other applications intended to support or sustain life or for any application where the failure of a Cactus Technologies[®] product can result in personal injury or death. Users of Cactus Technologies[®] products for such unintended and unauthorized applications shall assume all risk of such use and shall indemnify and hold Cactus Technologies[®] and its officers, employees, subsidiaries, affiliates and distributors harmless against all claims, costs, damages, expenses and attorney fees arising out of, directly or indirectly, any claim of personal injury or death associated with such unintended and unauthorized use, even if such claim alleges that Cactus Technologies[®] was negligent regarding the design or manufacture of the part.

All parts of the Cactus Technologies[®] documentation are protected by copyright law and all rights are reserved. This documentation may not, in whole or in part, be copied, photocopied, reproduced, translated, or reduced to any electronic medium or machine-readable form without prior consent, in writing, from Cactus Technologies[®], Limited.

© 2005-2023 Cactus Technologies[®] Limited. All rights reserved.

Table of Contents

1. Introduction to Cactus Technologies® Industrial 3D TLC -270PM6 Series M.2 SSD Products.....	5
1.1. Supported Standards.....	6
1.2. Product Features.....	6
1.2.1. Host and Technology Independence.....	6
1.2.2. Defect and Error Management.....	6
1.2.3. Power Supply Requirements.....	7
2. Product Specifications.....	7
2.1. System Environmental Specifications.....	7
2.2. System Power Requirements.....	7
2.3. System Performance.....	8
2.4. System Reliability.....	8
2.5. Physical Specifications.....	9
2.5.1. M.2 2242 SSD Physical Specifications.....	9
3. Interface Description.....	10
3.1. M.2 SSD Pin Assignments and Pin Type.....	10
4. Electrical Specifications.....	12
4.1.1. Absolute Maximum Ratings.....	12
4.1.2. DC Characteristics.....	12
4.1.3. AC Characteristics.....	13
5. PCI Configuration.....	13
5.1. PCI Express Capabilities.....	14
5.2. NVM Express Registers.....	15
5.2.1. Controller Capabilities (CAP).....	16
5.2.2. Version (VS).....	16
5.2.3. Interrupt Mask Set (INTMS).....	16
5.2.4. Interrupt Mask Clear (INTMC).....	17
5.2.5. Controller Configuration (CC).....	17
5.2.6. Controller Status (CSTS).....	17
5.2.7. NVM Subsystem Reset (NSSR).....	18
5.2.8. Admin Queue Attributes (AQA).....	18
5.2.9. Admin Submission Queue Base Address (ASQ).....	18
5.2.10. Admin Completion Queue Base Address (ACQ).....	19
5.2.11. Controller Buffer Memory Location (CMBLOC).....	19
5.2.12. Controller Buffer Memory Size (CMBSZ).....	19
5.2.13. Boot Partition Info (BPINFO).....	20
5.2.14. Boot Partition Read Select (BPRSEL).....	20
5.2.15. Boot Partition Memory Buffer Location (BPMBL).....	20
5.2.16. Submission Queue y Tail Doorbell (SQyTDBL).....	20
5.2.17. Completion Queue y Head Doorbell (CQyHDBL).....	20
6. Identify Command.....	20
6.1. Identify Controller Data Structure.....	21
7. SMART Reporting.....	24
7.1. SMART Attributes.....	24

8. Device Features.....25

9. Ordering Information.....28

Appendix A. Technical Support Services.....29

Appendix B. Cactus Technologies® Worldwide Sales Offices.....30

Appendix C. Limited Warranty.....31

1.Introduction to Cactus Technologies® Industrial 3D TLC -270PM6 Series M.2 SSD Products

Features:

- Solid state design with no moving parts
- conformal coated
- Equipped with heat spreader (standard temp. version) or heat sink (extended temp. version) for thermal management
- Capacities of 128/256/512GB
- Available in M.2 2242 form factor
- Native NVMe interface
- Compliant with PCI Express base specifications, ver.3.1
- Compliant with NVMeExpress specifications, ver.1.3
- PCI Express Gen3 x4 configuration
- Supports ASPM L1.0, L1.1, L1.2
- Supports NVMe defined SMART attributes
- Supports 16 I/O queues w/ max. queue depth of 32 each
- LDPC error correction
- End-to-End datapath protection
- -40°C to 85°C operation
- Voltage support: 3.3V±5%

Cactus Technologies® Industrial 3D TLC M.2 PCIe SSD is a high capacity solid-state flash memory product that complies with the PCI Express base standard v3.1 and NVM Express v1.3 standard. It is a PCIe device that operates in native NVMe mode. Cactus Technologies® Industrial 3D TLC M.2 SSD provides up to 512GB of formatted storage capacity.

Cactus Technologies® Industrial 3D TLC M.2 SSD product uses high quality industrial grade 3D TLC (gTLC) NAND flash memory from Kioxia Corporation. In addition, it includes an on-drive intelligent controller that manages interface protocols, data storage and retrieval as well as ECC, defect handling and diagnostics, power management, and clock control. The controller's firmware is upgradeable, thus allowing feature enhancements and firmware updates while keeping the BOM stable.

1.1. Supported Standards

Cactus Technologies® M.2 SSD is fully compatible with the following specification:

- PCI Express base specification, ver. 3.1, published by PCI-SIG
- NVM Express Specification 1.3 published by NVM Express Organization

1.2. Product Features

Cactus Technologies® Industrial 3D TLC M.2 SSD contains a high level, intelligent controller. This intelligent controller provides many capabilities including the following:

- Standard NVMe register and command set
- Manages details of erasing and programming flash memory independent of the host system
- Sophisticated defect managing capabilities (similar to magnetic disk drives).
- Sophisticated system for error recovery using powerful error correction code (ECC).
- Intelligent power management for low power operation.

1.2.1. Host and Technology Independence

Cactus Technologies® Industrial 3D TLC M.2 SSD operates in native NVMe mode. To write or read to the device, the host computer software simply issues a PCI memory Read or Write command to the drive as per the PCI Express protocol. The host software then waits for the command to complete. The host system does not get involved in the details of how the flash memory is erased, programmed or read as this is all managed by the built-in controller in the drive. Also, with the intelligent on-board controller, the host system software will not require changing as new flash memory evolves. Thus, systems that support the Cactus Technologies® Industrial 3D TLC M.2 SSD products today will continue to work with future Cactus Technologies® Industrial 3D TLC M.2 SSDs built with new flash technology without having to update or change host software.

1.2.2. Defect and Error Management

Cactus Technologies® Industrial 3D TLC M.2 SSD contains a sophisticated defect and error management system similar to those found in magnetic disk drives. The defect management is completely transparent to the host and does not consume any user data space. The soft error rate for Cactus Technologies® Industrial 3D TLC M.2 SSD is much lower than that of magnetic disk drives. In the extremely rare case where a read error does occur, the drive has sophisticated ECC to recover the data. These defect and error management systems, coupled with the solid-state construction, give Cactus Technologies® Industrial 3D TLC M.2 SSDs unparalleled reliability.

1.2.3. Power Supply Requirements

Cactus Technologies® Industrial 3D TLC M.2 SSD operates at a voltage range of 3.3 volts ± 5%.

2. Product Specifications

For all the following specifications, values are defined at ambient temperature and nominal supply voltage unless otherwise stated.

2.1. System Environmental Specifications

Table 2-1. Environmental Specifications

		Cactus Technologies® Industrial 3D TLC M.2 SSD
Temperature	Operating:	0°C to 70°C (standard temp.) -40° C to +85° C (extended temp.)
Humidity	Operating & Non-Operating:	8% to 95%, non-condensing
Vibration	Operating & Non-Operating:	16.4G, MIL-STD-810F Method 514.5, Procedure 1
Shock	Operating & Non-Operating:	50 G, MIL-STD-810F Method 516.5, Procedure 1
Altitude (relative to sea level)	Operating & Non-Operating:	100,000 feet maximum

2.2. System Power Requirements

Table 2-2. Power Requirements

		Cactus Technologies® Industrial 3D TLC M.2 SSD		
		128GB	256GB	512GB
DC Input Voltage (VCC) 100 mV max. ripple (p-p)		3.3V ±5%		
(Maximum Average Value) See Notes.	Idle:	190mA	200mA	190mA
	Read:	1040mA	1130mA	1130mA
	Write	880mA	1010mA	1140mA

NOTES: All values quoted are typical at ambient temperature and nominal supply voltage unless otherwise stated.

Idle mode is specified under the condition that all drive inputs are static CMOS levels and in a “Not Busy” operating state.

2.3. System Performance

All performance timings assume the drive controller is in the default (i.e., fastest) mode.

The IOPS numbers are steady state values when the SLC cache partition is already full.

Note: Due to the high throughput of PCIe interface, the drive controller implements thermal throttling to prevent excessive die temperature which will damage the device. Thermal throttling will kick in when internal die temperature reaches 90°C. The drive's rd/wr performance will drop significantly when thermal throttling kicks in. It is advised that the user provides adequate air flow in their system to reduce the likelihood of thermal throttling from happening.

Table 2-3. Performance

	128GB	256GB	512GB
Seq. Read (25°C)	1.4GB/s	1.6GB/s	1.6GB/s
Seq. Read (70°C standard temp.) (85°C extended temp.)	1.0GB/s	1.0GB/s	1.0GB/s
Seq. Write (SLC partition)	500MB/s	1GB/s	1.4GB/s
Seq. Write (TLC partition)	140MB/s	250MB/s	500MB/s
Seq. Write (70°C standard temp.) (85°C extended temp.)	500MB/s	780MB/s	850MB/s
Random 4K read Queue depth=32	100MB/s	190MB/s	300MB/s
Random 4K write Queue depth=32	7MB/s	15MB/s	24MB/s
Random 4K read IOPS Queue depth=32	26000	47000	76000
Random 4K write IOPS Queue depth=32	1700	3600	5900

2.4. System Reliability

Table 2-4. Reliability

Data Reliability	< 1 non-recoverable error in 10 ¹⁴ bits READ
Endurance (estimated TBW):	Up to:
128GB	384TB
256GB	768TB
512GB	1536TB

Note: estimated TBW assumes workload consisting of mostly large block writes; estimated TBW will be significantly reduced for workloads consisting of mostly random, small block writes. Data retention requirements are not considered in this estimation.

2.5. Physical Specifications

The following sections provide the physical specifications for Cactus Technologies® Industrial 3D TLC M.2 SSD products.

2.5.1. M.2 2242 SSD Physical Specifications

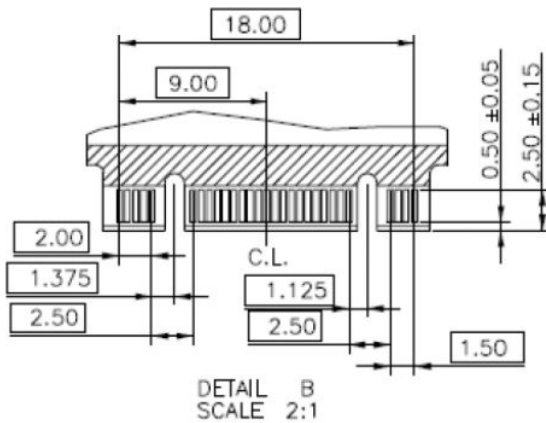
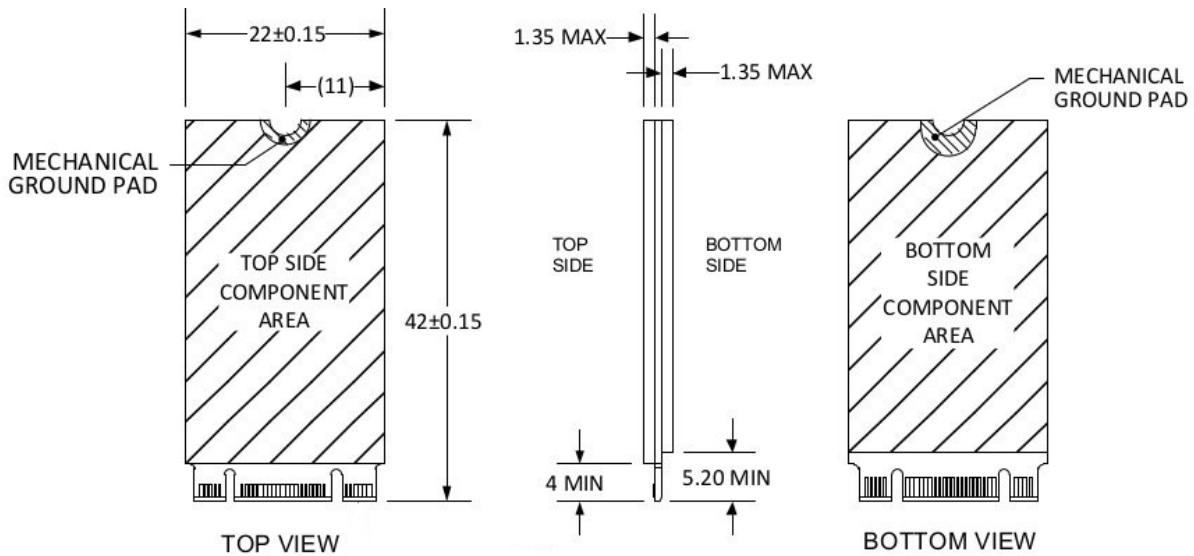

Note: the top side thickness is without the heat spreader. Heat spreader adds approximately 0.4 mm to the thickness.

2-1. M.2 2242 SSD Dimensions

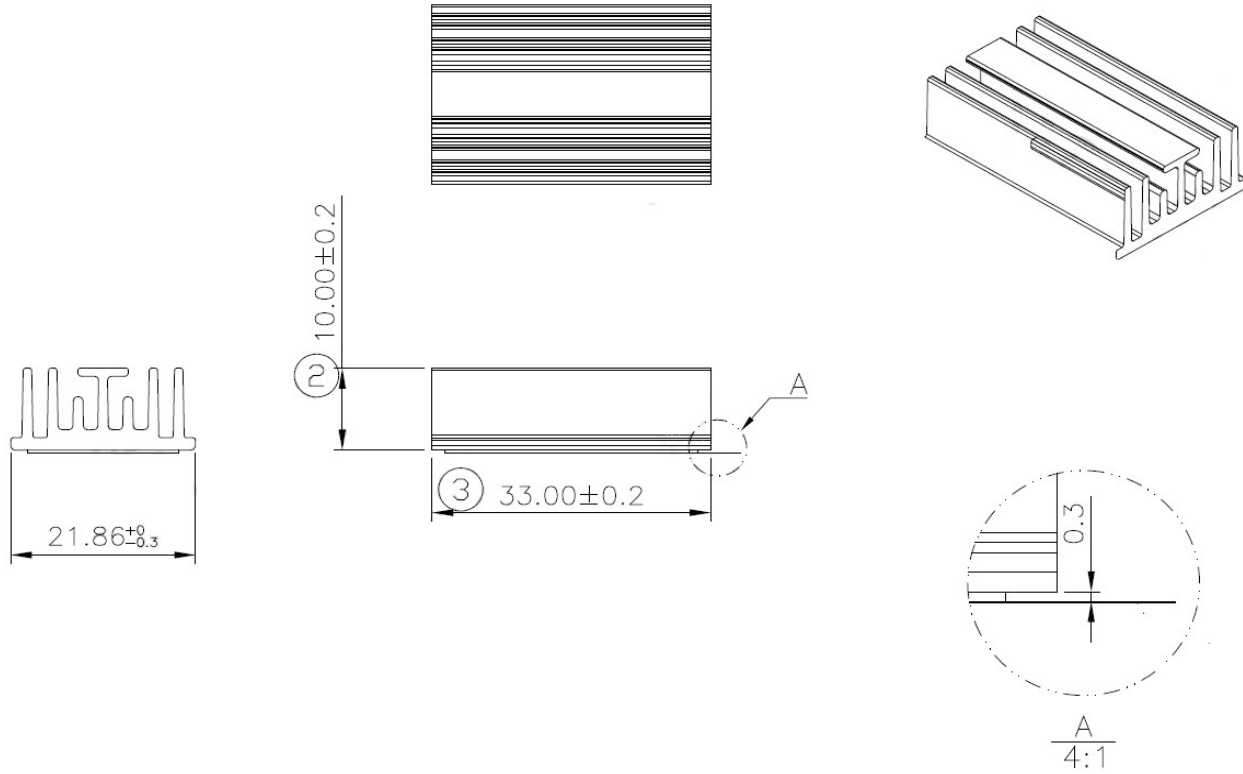

2-2. M.2 2242 SSD Heat Sink Dimensions (for extended temp. version)

3. Interface Description

The following sections provide detailed information on the Cactus Technologies® Industrial 3D TLC M.2 SSD interface.

3.1. M.2 SSD Pin Assignments and Pin Type

The signal/pin assignments and descriptions are listed in Table 3-5. Note that the pinout definitions are from the perspective of the device.

Table 3-5. M.2 SSD Pin Assignments and Pin Type

Cactus Technologies, Limited

Pin #	Pin Name	Description	Pin #	Pin Name	Description
1	GND		2	3.3V	3.3V supply
3	GND		4	3.3V	
5	PETn3		6	Reserved	
7	PETp3		8	Reserved	
9	GND		10	LED1#	LED for Drive activity
11	PERn3		12	3.3V	
13	PERp3		14	3.3V	
15	GND		16	3.3V	
17	PETn2		18	3.3V	
19	PETp2		20	Reserved	
21	GND		22	Reserved	
23	PERn2		24	Reserved	
25	PERp2		26	Reserved	
27	GND		28	Reserved	
29	PETn1		30	Reserved	
31	PETp1		32	Reserved	
33	GND		34	Reserved	
35	PERn1		36	Reserved	
37	PERp1		38	Reserved	
39	GND		40	Reserved	
41	PETn0		42	Reserved	
43	PETp0		44	Reserved	
45	GND		46	Reserved	
47	PERn0		48	Reserved	
49	PERp0		50	PERST#	PCIe reset
51	GND		52	CLKREQ#	PCIe clock request
53	REFCLKn	PCIe Reference Clock	54	PEWAKE#	Not used
55	REFCLKp		56	MFG_1	Reserved for manufacturer use
57	GND		58	MFG_2	Reserved for manufacture use
59			60		

Pin #	Pin Name	Description	Pin #	Pin Name	Description
61	M Key		62	M Key	
63					
65					
67	DNU		68	SUSCLK	32kHz clock input; not used
69	NC		70	3.3V	
71	GND		72	3.3V	
73	GND		74	3.3V	
75	GND		76		

4. Electrical Specifications

The following table defines all D.C. Characteristics for the M.2 SSD products. Unless otherwise stated, conditions are:

$$V_{cc} = 3.3V \pm 5\%$$

$$T_a = -40^{\circ}C \text{ to } 85^{\circ}C$$

4.1.1. Absolute Maximum Ratings

Parameter	Symbol	MIN	MAX	Units
Storage Temperature	T _s	-55	100	°C
Operating Temperature	T _A	-40	85	°C
V _{cc} with respect to GND	V _{cc}	-0.3	3.6	V

4.1.2. DC Characteristics

Parameter	Symbol	MIN	MAX	Units
Input Voltage	V _{in}	-0.5	V _{cc} + 0.5	V
Output Voltage	V _{out}	-0.3	V _{cc} + 0.3	V
Input Leakage Current	I _{LI}	-10	10	uA
Output Leakage Current	I _{LO}	-10	10	uA
Input/Output Capacitance	C _i /C _o		10	pF
Operating Current	I _{cc}			mA
Idle			210	
Active			1160	

4.1.3. AC Characteristics

Cactus Technologies® M.2 SSD products conforms to all AC timing requirements as specified in the PCI Express base specifications. Please refer to that document for details of AC timing for all operation modes of the device.

5. PCI Configuration

Cactus Technologies® M.2 SSD is a PCIe device. The following table shows the PCI Configuration Register values for this device:

address	Bit[31:24]	Bit[23:16]	Bit[15:8]	Bit[7:0]
00h	Device ID : 2263h		Vendor ID: 1E3Ah	
04h	Status: 0010h		Command	
08h	Class Code : 010802h Mass Storage Controller Non-volatile Memory NVM Express			Revision ID: 03h
0Ch	BIST	Header Type: 00h	Latency Timer:	Cacheline Size
10h	Base Address Registers			
14h				
18h				
1Ch				
20h				
24h				
28h	Cardbus CIS Pointer: N/A			
2Ch	Subsystem ID: 2263h		Subsystem Vendor ID: 1E3Ah	
30h	Expansion ROM Base Address			
34h	Reserved			Capabilities Pointer: N/A
38h	Reserved			

address	Bit[31:24]	Bit[23:16]	Bit[15:8]	Bit[7:0]
3Ch	Max Lat: 00h	Min Gnt: 00h	Interrupt Pin	Interrupt Line

5.1. PCI Express Capabilities

Cactus Technologies® Industrial 3D TLC grade M.2 SSD supported PCI Express capabilities are listed in the following table, please consult PCI Express Specifications for detailed explanation of the capabilities:

Capability	Register	Description
PCI Express		Ver. 2; PCIe Endpoint; Slot not Implemented
	Device Capabilities	Max. payload size: 128 bytes; Phantom Function Supported: 0; Extended Tag Field supported: 5-bit; EndPoint L0s latency: unlimited; EndPoint L1 latency: unlimited; Role-based Error Reporting: supported; Slot Power Limit: 75W; Function Level Reset: supported
	Device Control	Set by host
	Device Status	Reported Status: Correctable Error Detected, Non-Fatal Error Detected, Fatal Error Detected, Unsupported Request Detected, Aux Power Detected, Transaction Pending
	Link Capabilities	8GT/s, 4 lanes; ASPM L1 supported; L0s Exit Latency: 512ns - 1us; L1 Exit Latency: 4 - 8us; Clock Power Management: supported; Surprise Down Error Reporting: not supported; Data Link Layer Link Active Reporting: not supported; Link Bandwidth Notification: not supported; ASPM: supported
	Link Control	Set by host
	Link Status	Reported Status: Current Link Speed, Negotiated Link Width, Slot Clock Configuration
	Device Capabilities 2	Completion Timeout Range: ABCD; Completion Timeout Disable: supported; LTR Mechanism: supported; OBFF: not supported; Extended Fmt Field: not supported
	Device Control 2	Set by host
	Link Capabilities 2	Supported Link Speeds: 2.5/5.0/8.0 GT/s; Crosslinks: not supported
	Link Control 2	Set by host

Capability	Register	Description
	Link Status 2	Reported Status: Current De-emphasis Level, Equalization Complete, Equalization Phase 1 Successful, Equalization Phase 2 Successful, Equalization Phase 3 Successful, Link Equalization Request
MSI		64-bit address capable; Per vector masking supported
MSI-X		MSI-X table size: 16; Per Vector Mask Bit
Power Management		Complies with v3 of PCI Power Management Interface; DSI not required; PME# not supported; PME# assertion in D0, D1, D2, D3 not supported; Aux Current Required=0
	Power Management Control/Status	Reported Status: No_Soft_Reset
Extended Capabilities	Latency Tolerance Reporting	Capability version 1; Max Snoop Latency: 71680ns; Max No-Snoop Latency: 71680ns
	L1 PM Substate	Version 1; PCI-PM L1.1, L1.2 supported; ASPM L1.1, L1.2 supported; L1 PM Substates supported; Port Common Mode Restore Time: 10us; Port T_Power_On Value: 10us
	L1 PM Substate Control 1	Set by host
	L1 PM Substate Control 2	Set by host
	Advanced Error Reporting	Capability version 2; Implemented Registers: Uncorrectable Error Status, Uncorrectable Error Mask, Uncorrectable Error Severity, Correctable Error Status, Correctable Error Mask, Advanced Error Capabilities and Control, Header Log
Secondary PCI Express Extended Capability		Capability version 1;
	Link Control 3	Set by host
	Lane Error Status	
	Lane Equalization Control	Set by host, one register per lane

5.2. NVM Express Registers

The following sections describe the NVMe register contents of Cactus Technologies® Industrial 3D TLC grade M.2 SSD.

5.2.1. Controller Capabilities (CAP)

This 64-bit register indicates basic capabilities of the controller.

Bit(s)	Name	Value	Description
63:56			Reserved
55:52	MPSMAX	0	Memory Page Size Max: 8192
51:48	MPSMIN	0	Memory Page Size Min: 4096
47:46			Reserved
45	BPS	0	Boot Partition: not supported
44:37	CSS	1	Command Set Supported: NVM command set
36	NSSRS	0	NVMe Subsystem Reset Supported: Yes
35:32	DSTRD	0	Doorbell Stride: 4 bytes, this indicates there is no gap between doorbells registers
31:24	TO	78h	TimeOut for CSTS.RDY to switch states: 120s
23:19			Reserved
18:17	AMS	00	Arbitration Mechanism Supported: Round robin
16	CQR	1	Contiguous Queue Required. I/O submission and completions queues must be physically contiguous.
15:0	MQES	3FFFh	Max. Queue Entries Supported for I/O queues: 16384

5.2.2. Version (VS)

This 32-bit register indicates the NVMe Specification supported by the device. Cactus Technologies® Industrial 3D TLC grade M.2 SSD supports NVMe Specification v1.3.

Bit(s)	Name	Value	Description
31:16	MJR	0001h	Major Version Number: 1
15:8	MNR	03h	Minor Version Number: 3
7:0	TER	0	Tertiary Version Number: 0

5.2.3. Interrupt Mask Set (INTMS)

This 32-bit register is used to mask interrupts if legacy or MSI interrupts are used, this register is not used if MSI-X interrupts are used.

Bit(s)	Name	Value	Description
31:0	IVMS		Interrupt Vector Mask Set. Each bit that is set to '1' masks the corresponding interrupt vector.

5.2.4. Interrupt Mask Clear (INTMC)

This 32-bit register is used to clear interrupt masks if legacy or MSI interrupts are used, this register is not used if MSI-X interrupts are used.

Bit(s)	Name	Value	Description
31:0	IVMC		Interrupt Vector Mask Clear. Each bit that is set to '1' clears the corresponding interrupt vector mask.

5.2.5. Controller Configuration (CC)

This 32-bit register is written by the host to modify settings for the drive controller.

Bit(s)	Name	Value	Description
31:24			Reserved
23:20	IOCQES		I/O Completion Queue Entry Size
19:16	IOSQES		I/O Submission Queue Entry Size
15:14	SHN		Shutdown Notification
13:11	AMS		Arbitration Mechanism Selected
10:7	MPS		Memory Page Size
6:4	CSS		I/O Command Set Selected
3:1			Reserved
0	EN		Enable. Host writes '1' to this bit to enable the device to start processing commands.

5.2.6. Controller Status (CSTS)

This 32-bit register provides status information of the drive controller.

Bit(s)	Name	Value	Description
31:6			Reserved

Bit(s)	Name	Value	Description
5	PP		Process Paused. When set to '1', it indicates the drive controller has stopped processing commands
4	NSSRO		NVM Subsystem Reset Occurred. When set to '1', it indicates a reset has occurred while powered up.
3:2	SHST		Shutdown Status. 00b: Normal, no shutdown requested; 01b: shutdown processing occurring; 10b: shutdown processing complete; 11b: reserved
1	CFS		Controller Fatal Status. A value of '1' indicates a fatal controller error has occurred.
0	RDY		Ready. A value of '1' indicates the drive controller is ready to accept commands

5.2.7. NVM Subsystem Reset (NSSR)

Host writes a value of 4E564D65h to this register to request a NVM Subsystem Reset. A write of any other values to this register has no effect. A read of this register always returns zeroes. This register is supported only if the NSSRS bit is set.

5.2.8. Admin Queue Attributes (AQA)

This 32-bit register contains attributes for the Admin Submission and Completion queues.

Bit(s)	Name	Value	Description
31:28			Reserved
27:16	ACQS		Admin Completion Queue Size: 32
15:12			Reserved
11:0	ASQS		Admin Submission Queue Size: 32

5.2.9. Admin Submission Queue Base Address (ASQ)

This 64-bit register is written by the host to set the Admin Submission Queue Base Address.

5.2.10. Admin Completion Queue Base Address (ACQ)

This 64-bit register is written by the host to set the Admin Completion Queue Base Address.

5.2.11. Controller Buffer Memory Location (CMBLOC)

This 32-bit register contains the location of the drive's Controller Buffer Memory. If the Controller Buffer Memory Size (CMBSZ) register content is zero, this register is reserved.

Bit(s)	Name	Value	Description
31:12	OFST		Offset. This indicates the offset of the Controller Buffer Memory in multiples of the size unit indicated in CMBSZ. This value is 4KB aligned.
11:3			Reserved
2:0	BIR		Base Indicator Register. This indicates the Base Address Register (BAR) that contains the Controller Buffer Memory.

5.2.12. Controller Buffer Memory Size (CMBSZ)

This 32-bit register defines the size of the drive's Controller Buffer Memory.

Bit(s)	Name	Value	Description
31:12	SZ	0	Size. This indicates the size of the Controller Buffer Memory in multiples of the size unit indicated in bit[2:0]. Cactus Technologies® M.2 SSD does not support Controller Buffer Memory.
11:8	SZU	0	Size Unit.
7:5			Reserved
4	WDS	0	Write Data Support. All write data must be transferred from host memory.
3	RDS	0	Read Data Support. All read data must be transferred to host memory.
2	LISTS	0	PRP SGL Support. All PRP and SGL lists must be placed in host memory.
1	CQS	0	Completion Queue Support. All Completion Queues must be placed in host memory.
0	SQS	0	Submission Queue Support. All Submission Queues must be placed in host memory.

5.2.13. Boot Partition Info (BPINFO)

Cactus Technologies® M.2 SSD does not support Boot Partition, this register will read back zeroes.

5.2.14. Boot Partition Read Select (BPRSEL)

Cactus Technologies® M.2 SSD does not support Boot Partition, this register will read back zeroes.

5.2.15. Boot Partition Memory Buffer Location (BPMBL)

Cactus Technologies® M.2 SSD does not support Boot Partition, this register will read back zeroes.

5.2.16. Submission Queue y Tail Doorbell (SQyTDBL)

This 32-bit register defines the Tail entry pointer for submission queue y. There is one tail doorbell register for each submission queue. The register for queue y is located at $(1000h + ((2y)*(4 \ll CAP.DSTRD)))$.

Bit(s)	Name	Value	Description
31:16			Reserved
15:0	SQT		Submission Queue Tail

5.2.17. Completion Queue y Head Doorbell (CQyHDBL)

This 32-bit register defines the Head entry pointer for completion queue y. There is one head doorbell register for each completion queue. The register for queue y is located at $(1000h + ((2y+1)*(4 \ll CAP.DSTRD)))$.

Bit(s)	Name	Value	Description
31:16			Reserved
15:0	CQH		Completion Queue Head

6. Identify Command

The Identify command is an Admin command that retrieves information about the NVM subsystem. The returned structure is 4096 bytes and the following section describes the contents of this structure in Cactus Technologies® Industrial 3D TLC grade M.2 SSDs.

6.1. Identify Controller Data Structure

Byte(s)	Name	Value	Description
1:0	VID	1E3Ah	PCI Vendor ID. This is PCISIG assigned Vendor ID for Cactus Technologies®
3:2	SSVID	1E3Ah	PCI Subsystem ID.
23:4	SN	varies	This field returns product specific serial number.
63:24	MN	Fixed	This field returns manufacturer's name. For this product, the returned string is: CactusFlashCard
71:64	FR	varies	Firmware version.
72	RAB	6	Recommended Arbitration Burst size in bytes.
75:73	IEEE	0	IEEE OUI Identifier. Not applicable for this product.
76	CMIC	0	Controller Multipath I/O and Namespace Sharing Capabilities: Single Port, Single Controller, PCI function.
77	MDTS	5	Max. Data Transfer Size: 2 ⁵ x MPSMIN
79:78	CNTLID	1	Controller ID.
83:80	VER	10300h	Version: NVM Express 1.30
87:84	RTD3R	7A120h	RTD3 Resume Latency. Resume time from Runtime D3 : 500ms
91:88	RTD3E	1E8480h	RTD3 Entry Latency. Latency to enter Runtime D3: 2s
95:92	OAES	200h	Optional Asynchronous Events Supported: Firmware Activation Notices supported
99:96	CTRATT	0	Controller Attributes: 128-bit host identifier not supported; Non-operational State Power State Permissive Mode not supported
239:100			Reserved
254:240			Reserved
255		0	Management Endpoint Capabilities: none
257:256	OACS	17h	Optional Admin Command Support Security Send & Receive commands: supported Format NVM command: supported Firmware commit and Download: supported Namespace management & Attachment commands: not supported Device Self-test: supported
258	ACL	4	Abort Command Limit
259	AERL	7	Asynchronous Event Request Limit
260	FRMW	14h	Firmware Updates: Firmware Slot 1 Rd/Wr; 2 firmware slots; firmware activation without reset supported
261	LPA	Fh	Log Page Attributes: SMART Log page per namespace supported, Command Effects Log page supported, Extended data for Get Log Page supported, Telemetry log page supported
262	ELPE	255	Error Log Page Entries
263	NPSS	4	Number of Power States Support
264	AVSCC	0	Admin Vendor Specific Command Configuration: Vendor Specific
265	APSTA	1	Autonomous Power State Transition Attributes: Autonomous Power State Transition supported
267:266	WCTEMP	348	Warning Composite Temperature Threshold: 348K (75C)

Byte(s)	Name	Value	Description
269:268	CCTEMP	353	Critical Compostie Temperature Threshold: 353K (80C)
271:270	MTFA	50	Max. Firmware Activation Time: 5s
275:272	HMPRE	0	Host Memory Buffer Prefer Size: HBM not supported
279:276	HMMIN	0	Host Memory Buffer Min. Size: HBM not supported
295:280	TNVMCAP	0	Total NVM Capacity: Not reported as Namespace Mangement & Attachment commands are not supported
311:296	UNVMCAP	0	Unallocated NVM Capacity: not reported
315:312	RPMBS	0	Replay Protected Memory Block Support: not supported
317:316	EDSTT	5	Extended Device Self-test Time: 5 mins
318	DSTO	1	Device Self-test Option: one device self-test operation at a time
319	FWUG	0	Firware Update Granularity: no information provided
321:320	KAS	0	Keep Alive Support: not supported
323:322	HCTMA	1	Host Controlled Thermal Management Attribute: supported
325:324	MNTMT	303	Min. Thermal Management Temperature: 30C
327:326	MXTMT	348	Max. Thermal Management Temperature: 75C
331:328	SANICAP	2	Sanitize Capabilities: Block Erase Sanitize supported
511:332			Reserved
512	SQES	66h	Submission Queue Entry Size. Required: 64, Max: 64
513	CQES	44h	Completion Queue Entry Size. Required: 16, Max: 16
515:514	MAXCMD	0	Max Outstanding Command: not applicable
519:516	NN	1	Number of Namespaces: 1
521:520	ONCS	5Fh	Optional NVM Command Support: Compare Command: supported Write Uncorrectable Command: supported Dataset Management Command: supported Write Zeroes Command: supported Save and Select Fields: supported Reservations: not supported Timestamp: supported
523:522	FUSES	0	Fused Operation Support: Fused Compare and Write operation not supported
524	FNA	0	Format NVM Attributes: Format applies to single namespace, Crypto and user data erase applies to single namespace, Cryptoerase not supported as part of Secure Erase
525	VWC	7	Volatile Write Cache: present
527:526	AWUN	0	Atomic Write Unit Normal: size of write unit guaranteed to be written atomically during normal operation
529:528	AWUPF	0	Atomic Write Unit Power Fail: size of write unit guaranteed to be written atomically during power fail or error condition
530	NVSCC	0	NVM Vendor Specific Command Configuration: Vendor specific
531			Reserved
533:532	ACWU	0	Atomic Compare & Write Unit: size of write unit guaranteed to be written atomically during a fused compare and write operation
535:534			Reserved
539:536	SGLS	0	SGL Support: not supported
767:540			Reserved

Byte(s)	Name	Value	Description
1023:768	SUBNQN		NVM Subsystem NVMe Qualified Name: not applicable
2047:1024			Reserved
2079:2048	PSD0		Power State 0 Descriptor: Max Power (MP): 9W Non-Operational State (NOPS): I/O commands operational Entry Latency (ENLAT): 0 Exit Latency (EXLAT): 0 Relative Read Throughput (RRT): 0 Relative Read Latency (RRL): 0 Relative Write Throughput (RWT): 0 Relative Write Latency (RWL): 0 Idle Power (IDL P): - Active Power (ACTP): -
2111:2080	PSD1		Power State 1 Descriptor: Max Power (MP): 4.6W Non-Operational State (NOPS): I/O commands operational Entry Latency (ENLAT): 0 Exit Latency (EXLAT): 0 Relative Read Throughput (RRT): 1 Relative Read Latency (RRL): 1 Relative Write Throughput (RWT): 1 Relative Write Latency (RWL): 1 Idle Power (IDL P): - Active Power (ACTP): -
2143:2112	PSD2		Power State 2 Descriptor: Max Power (MP): 3.8W Non-Operational State (NOPS): I/O commands operational Entry Latency (ENLAT): 0 Exit Latency (EXLAT): 0 Relative Read Throughput (RRT): 2 Relative Read Latency (RRL): 2 Relative Write Throughput (RWT): 2 Relative Write Latency (RWL): 2 Idle Power (IDL P): - Active Power (ACTP): -
2175:2144	PSD3		Power State 3 Descriptor: Max Power (MP): 0.045W Non-Operational State (NOPS): I/O commands non-operational Entry Latency (ENLAT): 2000us Exit Latency (EXLAT): 2000us Relative Read Throughput (RRT): 3 Relative Read Latency (RRL): 3 Relative Write Throughput (RWT): 3 Relative Write Latency (RWL): 3 Idle Power (IDL P): - Active Power (ACTP): -

Byte(s)	Name	Value	Description
2207:2176	PSD4		Power State 4 Descriptor: Max Power (MP): 0.004W Non-Operational State (NOPS): I/O commands not operational Entry Latency (ENLAT): 15000us Exit Latency (EXLAT): 15000us Relative Read Throughput (RRT): 4 Relative Read Latency (RRL): 4 Relative Write Throughput (RWT): 4 Relative Write Latency (RWL): 4
4095:2208			Reserved

7.SMART Reporting

Cactus Technologies® Industrial 3D TLC M.2 SSD supports SMART attribute reporting in the SMART Log Page using the Get Log Page Admin command. The attributes reported are shown below.

7.1. SMART Attributes

The following attributes are reported in the SMART Log page:

Attribute	Description
Critical Warning	Bit 0: if set to '1', this indicates available spare has fallen below threshold Bit 1: if set to '1', this indicates temperature has exceeded high temperature threshold or dropped below low temperature threshold Bit 2: if set to '1', this indicates excessive media error Bit 3: if set to '1', this indicates the drive is in read only mode Bit[7:4]: reserved
Temperature	Temperature in Kelvin
Available Spare	Percentage remaining spares
Available Spare Threshold	Warning flag is set if remaining spares drops below this threshold percentage
Percentage Used	This is a vendor specific estimation of the percentage life used for the device
Data Units Read	Number of 512bytes units read; each count represents 1000 units
Data Units Written	Number of 512bytes units written; each count represents 1000 units
Host Read Commands	Number of host read commands processed
Host Write Commands	Number of host write commands processed
Controller Busy Time	The amount of time the drive is busy processing I/O commands; the unit is in minutes
Power Cycles	Number of power cycles
Power On Hours	Number of Power On Hours
Unsafe Shutdowns	The number of power loss without prior Shutdown notification.
Media and Data Integrity Errors	Number of uncorrectable data errors

Attribute	Description
Number of Error Information Log Entries	Number of Error Information Log Entries over the product's life
Warning Composite Temperature Time	Amount of time in minutes that the drive is in operation above the Warning Temperature Threshold but below the Critical Temperature Threshold
Critical Composite Temperature Time	Amount of time in minutes that the drive is in operation above the Critical Temperature Threshold

8. Device Features

Features supported by Cactus Technologies® Industrial 3D TLC M.2 SSD are reported using the Get Features Admin command. The supported features are listed below:

Identifier	Name	Value	Description
1	Arbitration	6h	<p>This feature controls command arbitration.</p> <p>Bit[31:24]: High Priority Weight (HPW). This defines the number of commands that can be executed from the High Priority service class in each arbitration round.</p> <p>Bit[23:16]: Medium Priority Weight (MPW). This defines the number of commands that can be executed from the Medium Priority service class in each arbitration round.</p> <p>Bit[15:08]: Low Priority Weight (LPW). This defines the number of commands that can be executed from the Low Priority service class in each arbitration round.</p> <p>Bit[7:3]: Reserved</p> <p>Bit [2:0]: Arbitration Burst (AB). This indicates the max. number of commands the controller can launch at one time from a Submission Queue. Value specified is 2^n.</p>
2	Power Management	0	<p>This feature is used by the host to control the device power state. The returned content reflects the current power state attributes.</p> <p>Bit[31:8]: Reserved</p> <p>Bit [7:5]: Workload Hint (WH). This field indicates the type of workload expected; this is set by the host with the Set Feature command.</p> <p>Bit[4:0]: Power State (PS). This field indicates the power state the device should transition to. This is set by the host with the Set Feature command.</p>
3	LBA Range Type	0	<p>This field always returns zeroes on reads.</p>

Identifier	Name	Value	Description
4	Temperature Threshold	15Ch	<p>Bit[31:22]: Reserved</p> <p>Bit[21:20]: Threshold Type Select (THSEL). 00b – over temperature threshold; 01b – Under temperature threshold; 10b, 11b – Reserved.</p> <p>Bit[19:16]: Threshold Temperature Select (TMPSEL). 0000b – composite temperature; 0001b – 1000b : binary coded value of temperature sensor; 1001b – 1111b: Reserved</p> <p>Bit[15:0]: Temperature Threshold (TMPTH). Value indicated in °K.</p>
5	Error Recovery	0	<p>This field reflects Error Recovery options as set by the host.</p> <p>Bit[31:17]: Reserved</p> <p>Bit[16]: Deallocated or Unwritten Logical Block Error Enable (DULBE) – not enabled</p> <p>Bit[15:0]: Time Limited Error Recovery (TLER). This indicates a limited retry timeout value in units of 100ms.</p>
6	Volatile Write Cache	1	<p>Volatile Write Cache Enable (WCE). This field reflects the state of Volatile Write Cache as set by the host.</p> <p>Bit[31:1]: Reserved</p> <p>Bit[0]: If set, Volatile Write Cache is enabled.</p>
7	Number of Queues	000F000Fh	<p>Bit[31:16]: Number of I/O Completion Queue Allocated (NCQA).</p> <p>Bit[15:0]: Number of I/O Submission Queue Allocated (NSQA).</p> <p>These values reflect the max. number of queues the controller can support.</p>
8	Interrupt Coalescing	0	<p>Bit[31:16]: Reserved</p> <p>Bit[15:8]: Aggregation Time (TIME). Max. time in 100us units that the controller can delay an interrupt. 0 indicates no delay.</p> <p>Bit[7:0]: Aggregation Threshold (THR). This indicates the min. number of completion queue entries to aggregate before interrupting the host, value is n+1.</p>

Identifier	Name	Value	Description
9	Interrupt Vector Configuration	0	<p>This field returns status of Interrupt Vector Configuration as set by the host.</p> <p>Bit[31:17]: Reserved</p> <p>Bit[16]: Coalescing Disable (CD). If set to 1, interrupt coalescing is disabled for the Interrupt Vector indicated in bit[15:0].</p> <p>Bit[15:0]: Interrupt Vector (IV). This field indicates the Interrupt Vector applicable to this configuration.</p>
10	Write Atomicity Normal	0	<p>This field reflects the operations of AWUN and NAWUN parameters as set by the host.</p> <p>Bit[31:1]: Reserved</p> <p>Bit[0]: Disable Normal (DN). If set to 1, controller are not required to honor AWUN and NAWUN.</p>
11	Asynchronous Event Configuration	200h	<p>This field controls asynchronous event reporting as set by the host.</p> <p>Bit[31:10]: Reserved</p> <p>Bit[9]: Firmware Activation Notice. If set, firmware activation notices are to be sent to the host.</p> <p>Bit[8]: Namespace Attribute Notice. If set, namespace attribute change event notices are to be sent to the host.</p> <p>Bit[7:0]: SMART Critical Warning. If set, each corresponding critical warning bit in SMART Log will trigger notice to the host.</p>
12	Autonomous Power State Transition	0	<p>This feature reports power state transition settings.</p> <p>Bit[31:1]: Reserved.</p> <p>Bit[0]: Autonomous Power State Transition Enable (ASPTTE). If cleared, Autonomous Power State Transition is disabled. If set, transition attributes for each power state is returned in the Autonomous Power State Transition Structure.</p>

9. Ordering Information

Model KDXY-270PM6

Where: X is drive capacities:

128G ----- 128GB
256G ----- 256GB
512G ----- 512GB

Where: Y is temperature grade

Blank ----- standard temp. (comes with heat spreader)
I ----- extended temp. (comes with heat sink)

Example:

1. KD128GF-270PM6 ----- 128G standard temp. SSD
2. KD256GFI-270PM6 ----- 256G extended temp. SSD

Appendix A. Technical Support Services

A.1. Direct Cactus Technologies® Technical Support

Email: tech@cactus-tech.com

Appendix B.Cactus Technologies® Worldwide Sales Offices

Email: sales@cactus-tech.com

Email: americas@cactus-tech.com

Appendix C.Limited Warranty

I. WARRANTY STATEMENT

Cactus Technologies® warrants its Industrial Grade products only to be free of any defects in materials or workmanship that would prevent them from functioning properly for two years from the date of purchase or when rated TBW is exceeded, whichever occurs first. This express warranty is extended by Cactus Technologies® Limited to customers of our products.

II. GENERAL PROVISIONS

This warranty sets forth the full extent of Cactus Technologies® responsibilities regarding the Cactus Technologies® Industrial 3D TLC Grade Flash Storage Products. Cactus Technologies®, at its sole option, will repair, replace or refund the purchase price of the defective product. Cactus Technologies® guarantees our products meet all specifications detailed in our product manuals. Although Cactus Technologies® products are designed to withstand harsh environments and have the highest specifications in the industry, they are not warranted to never have failure and Cactus Technologies® does not warranty against incidental or consequential damages. Accordingly, in any use of products in life support systems or other applications where failure could cause injury or loss of life, the products should only be incorporated in systems designed with appropriate redundancy, fault tolerant or backup features.

III. WHAT THIS WARRANTY COVERS

For products found to be defective, Cactus Technologies® will have the option of repairing, replacing or refunding the purchase price the defective product, if the following conditions are met:

- A. The defective product is returned to Cactus Technologies® for failure analysis as soon as possible after the failure occurs.
- B. An incident card filled out by the user, explaining the conditions of usage and the nature of the failure, accompanies each returned defective product.
- C. No evidence is found of abuse or operation of products not in accordance with the published specifications, or of exceeding maximum ratings or operating conditions.

All failing products returned to Cactus Technologies® under the provisions of this limited warranty shall be tested to the product's functional and performance specifications. Upon confirmation of failure, each product will be analyzed, by whatever means necessary, to determine the root cause of failure. If the root cause of failure is found to be not covered by the above provisions, then the product will be returned to the customer with a report indicating why the failure was not covered under the warranty.

This warranty does not cover defects, malfunctions, performance failures or damages to the unit resulting from use in other than its normal and customary manner, misuse, accident or neglect; or improper alterations or repairs. Cactus Technologies® Limited may repair or replace, at its discretion, any product returned by its customers, even if such product is not covered under warranty, but is under no obligation to do so.

IV. RECEIVING WARRANTY SERVICE

According to Cactus Technologies® warranty procedure, defective product should be returned only with prior authorization from Cactus Technologies® Limited. Please contact Cactus Technologies® Customer Service department (tech@cactus-tech.com) with the following information: product model number and description, nature of defect, conditions of use, proof of purchase and purchase date. If approved, Cactus Technologies® will issue a Return Material Authorization or Product Repair Authorization number and instructions to ship the product back to us for service.